

Flow Chemistry

through Continuous Mechanochemical Synthesis

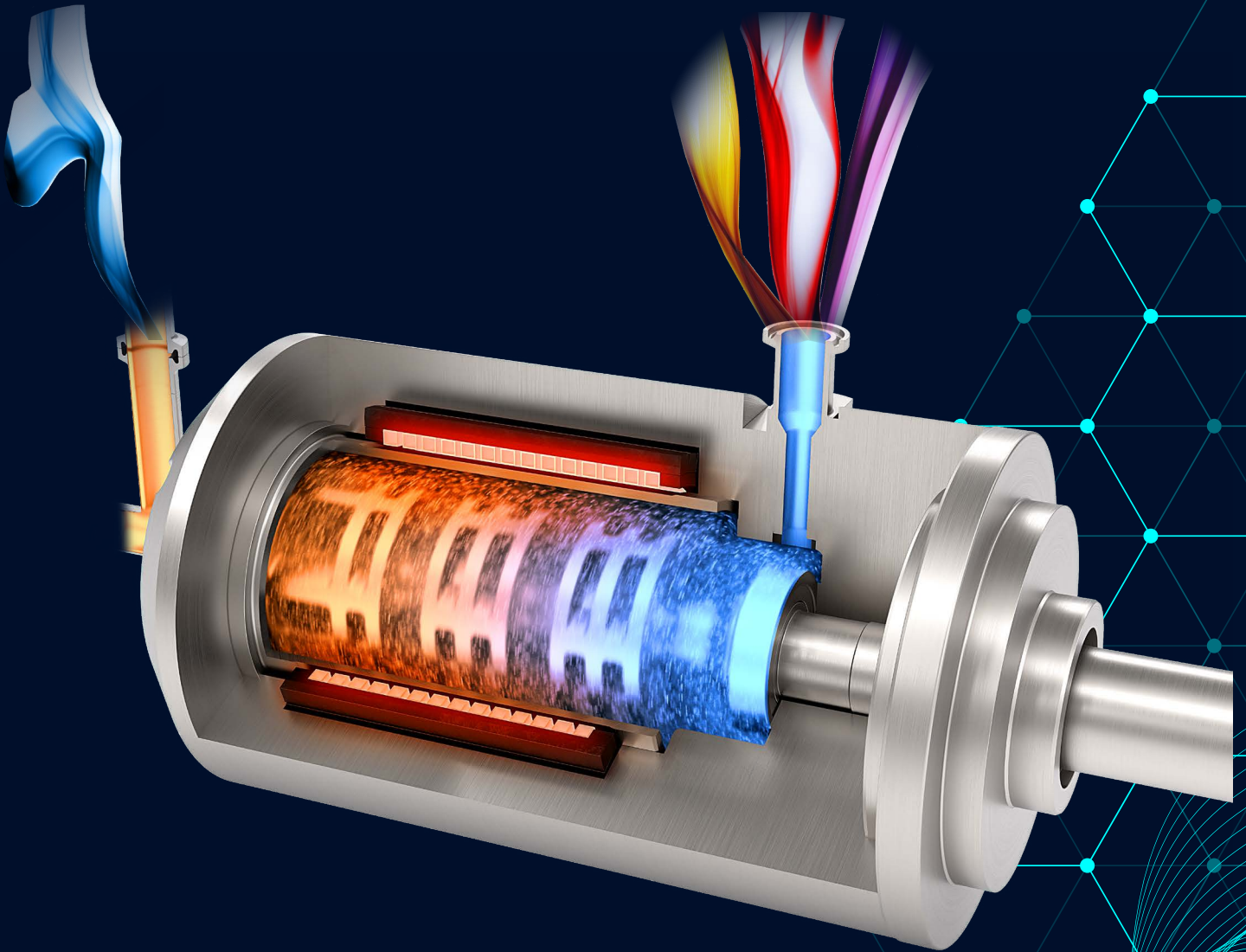

- Green chemistry
- Fully scalable
- Novel, patented technology

FLOW CHEMISTRY

In Flow Chemistry, chemical processes are taking place in a continuously flowing stream contrary to batch production. This offers several compelling advantages that can be highly beneficial in various industries.

The main advantages are:

- Better mass and heat transfer
- Faster reactions
- Increased quality (conversion, yield and selectivity)
- Broad scalability
- Higher sustainability
- Improved safety due to smaller reaction volume

MECHANOCHEMISTRY

Mechanochemical reactions are understood to be “chemical transformations initiated or sustained by mechanical force”.¹ It is considered as major technology to achieve the United Nations Goals for Sustainable Development (Agenda 2030).

The main advantages are:

- Possibility of solvent-free reactions
- Better mixing of primary materials
- Excellent surface renewal of the reactants
- Higher productivity
- Energy savings
- Cost savings
- Reactions can take place at lower temperatures

(1) J.-L. Do, T. Friščić, Mechanochemistry: A Force of Synthesis. *ACS Central Science* 2017 3 (1), 13-19.

THE SOLUTION

WAB MECHANOCHEMICAL REACTORS

Benefits of mechanochemical reactors with bead mill technology:

- Highest turbulences due to fast rotational speed up to 6'000 rpm
- Residence time independent from energy input
- High and very fast conversion, outstanding yield and selectivity
- Small reaction chamber with an exceptional surface to volume ratio
- Processing of dry, liquid, liquid assisted and viscous products
- Excellent surface renewal of the reactants trough bead mill technology
- Mechanical forces such as shock, pressure, shear, friction, impact and torsion apply
- Environmentally friendly by using
 - ✓ less resources
 - ✓ less solvents and generating less waste
 - ✓ less energy consumption
 - ✓ less space requirements
 - ✓ high level of automation
- Existing scale up from milligrams to tons
- Life-Cycle Analyses were carried out
- Energy input through mechanochemistry and additionally with inductive heating device



OUTSTANDING MECHANOCHEMISTRY

A mechanochemical reactor with 0.5 litre reaction volume filled with 0.8 mm diameter beads contains more than 800'000 beads. The high rotational speed of the accelerators speed-up the beads and create billions of impacts where shock, pressure, shear, friction, impact and torsion apply. These impacts enhance the chemical reaction and create a constant renewal of the surface of the reactants. The high turbulences lead to an excellent mixing, exceptional homogeneity and therefore fast conversion, outstanding yield and selectivity. The residence time is settable and independent from the energy input. This allows the process to be conducted at the optimum operating point.

Mechanical effects on molecules

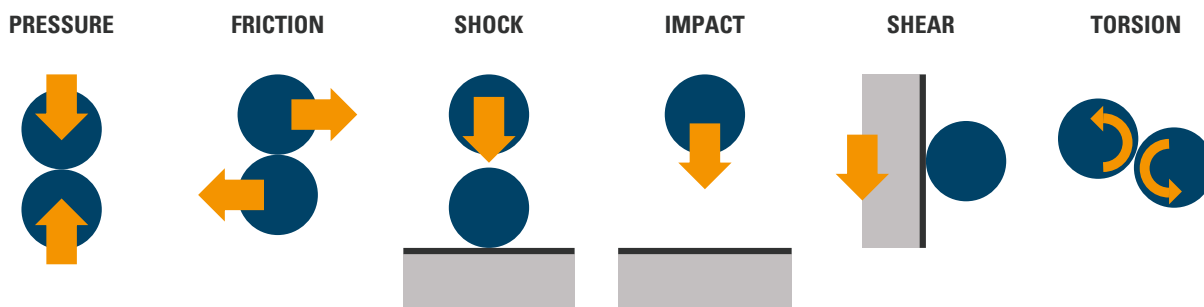

TOOLS FOR RESEARCH & DEVELOPMENT

DYNO[®]-MILL RESEARCH LAB

Small, efficient, versatile: The ideal starting equipment for Research & Development in mechanochemistry. It delivers high mechanical impacts and creates reproducible and upscalable chemical reactions.

Applications and advantages:

- 80 ml reactor volume for smallest quantities
- Processing of liquids, solids and powders
- Heating or cooling via the inlet funnel
- Easy machine operation and cleaning
- Parts in contact with product in metal or ceramic
- Logging of relevant process parameters
- GMP-conform design
- ATEX-version available
- Scale-up available
- Use as continuous flow or batch reactor

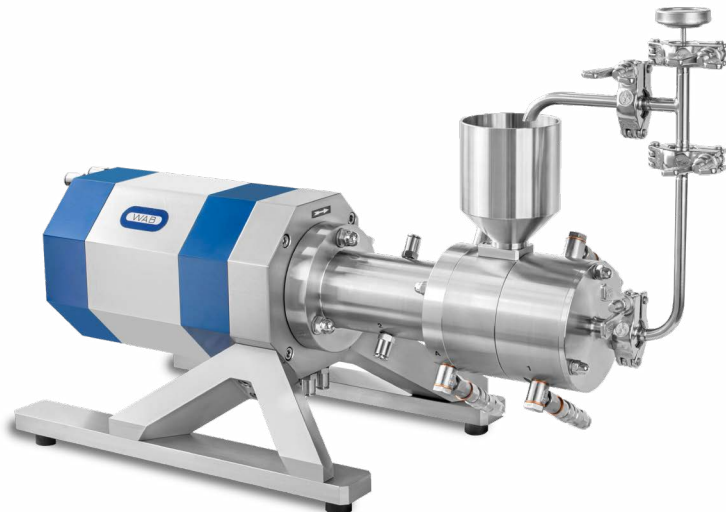

DYNO[®]-MILL MULTI LAB

Green and sustainable chemistry often utilises renewable, natural resources. The DYNO[®]-MILL MULTI LAB allows to process fibrous products in a mechanochemical reaction.

Applications and advantages:

- Reactor volume from 150 ml to 1.4 l
- Processing of liquids and fibrous products
- Easily cleanable gap separator
- Easy machine operation
- Parts in contact with product in metal or ceramic
- Logging of relevant process parameters
- GMP-conform design
- ATEX-version available
- Scale-up available



SCALE-UP: FROM LAB TO PRODUCTION

A key-factor after successful product development is the scale-up from laboratory to a pilot or production plant. The WAB specialists support you in scaling up your process.

- Existing scale-up from milligrams to tons
- Highest mechanical energy input technology
- Processing of liquid and viscous products
- Small reaction chamber with an exceptional surface to volume ratio
- Parts in contact with product in metal or ceramic
- High turbulances for exceptional homogeneity
- ATEX-compliant version available



DYNO®-MILL UNI LAB



DYNO®-MILL ECM-AP 2



DYNO®-MILL ECM-AP 10



DYNO®-MILL ECM-AP 20



DYNO®-MILL ECM-AP 60

| Type | UNI LAB | ECM-AP 2 | ECM-AP 10 | ECM-AP 20 | ECM-AP 60 |
|---------------------------|-----------------|-------------------|--------------------|--------------------|--------------------|
| Reactor Volume (litre) | 0.53 | 1.9 | 9 | 21 | 62 |
| Reactor Drive (kW) | 4 | 11 | 37 | 55 | 110 |
| Weight (kg) | 140-160 | 600-700 | 1200-1300 | 2000-2300 | 4100-4300 |
| Dimensions L x B x H (mm) | 895 x 725 x 730 | 1290 x 850 x 1650 | 1520 x 1000 x 1920 | 1990 x 1310 x 2150 | 2330 x 1340 x 2220 |

HIGH TEMPERATURE VERSION WAB IMPA[°]CT REACTOR[®]

The **WAB IMPA[°]CT REACTOR[®]** sets the ultimate benchmark in the field of continuous flow mechanochemistry. An inductive heating system arranged around the accelerators enables direct and efficient heating of the reactants up to +160°C with an accuracy of +/- 0.5°C. Together with the impact beads located in the reactor chamber, the **WAB IMPA[°]CT REACTOR[®]** is a ground-breaking, user friendly and application-specific apparatus for molecular synthesis by means of mechanochemistry.

UP TO 160°C



THE WORKING PRINCIPLE

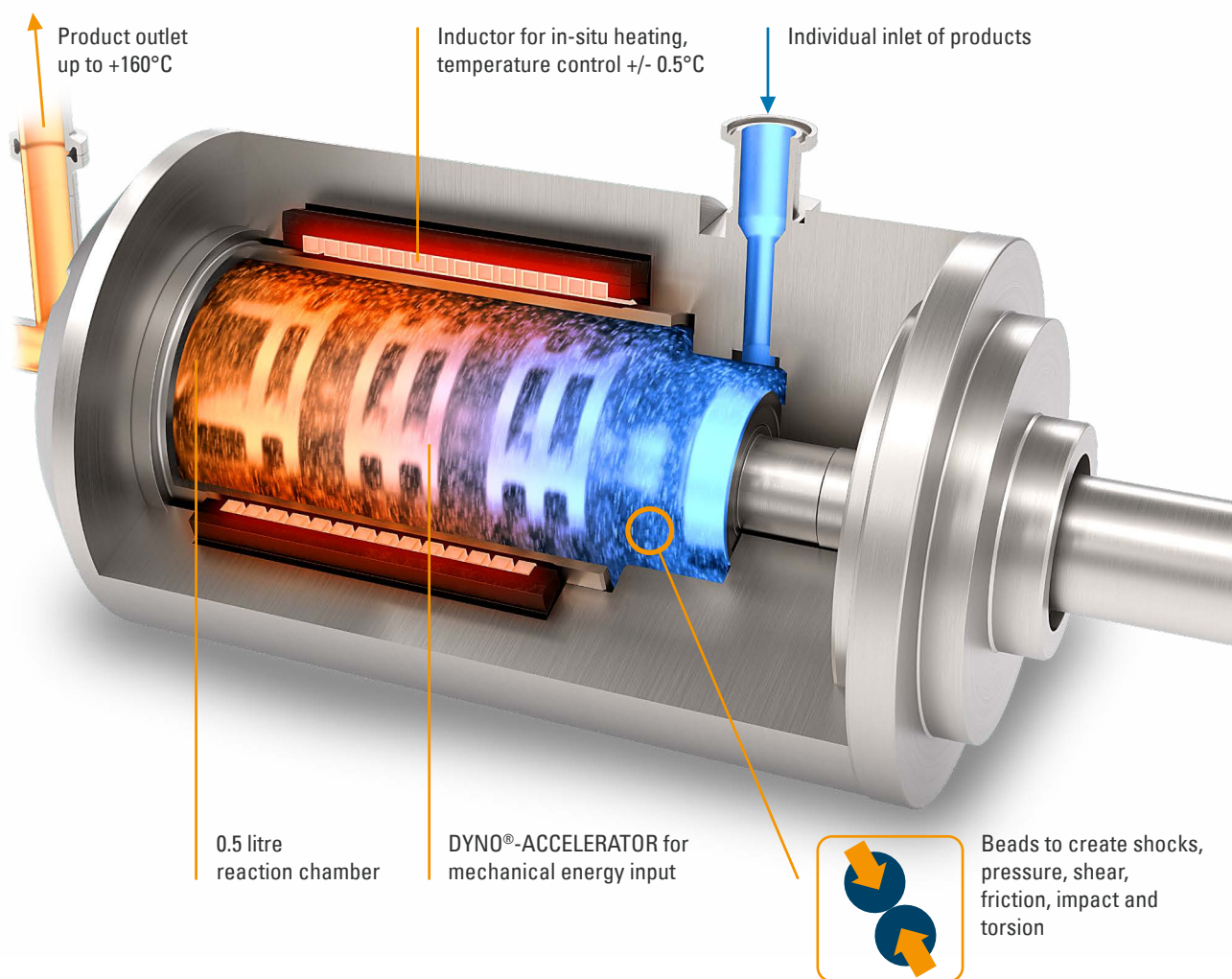

READY-TO-USE PRODUCTION SOLUTION

The **WAB IMPA[°]CT REACTOR[®]** is supplied as a complete process system consisting of an inductively heated mechanochemical reactor, dedicated product pumps, mobile operator control panel and accessories.

The control panel provides full flexibility to operate the reactor from hand-mode up to fully automated production mode. It controls and logs all production parameters such as a product temperature, product pressure, flow rate, product dosing and many more.



TECHNOLOGY ADVANTAGES

The **WAB IMPA[°]CT REACTOR[®]** provides several technology advantages:

- Max. controllable product temperature: +160°C
- Temperature control: $\pm 0.5^{\circ}\text{C}$
- Product flow range: 0.15 to 150 litre/h
- Max. operating pressure: +2 bar (higher pressure on request)
- Bead size diameter: 0.1 to 2 mm
- Max. operating speed: 4'775 rpm
- Centrifugal force: > 400 g
- Number of beads: > 800'000 with a diameter 0.8 mm
- Logging and control of all process parameters
- Scalable to production

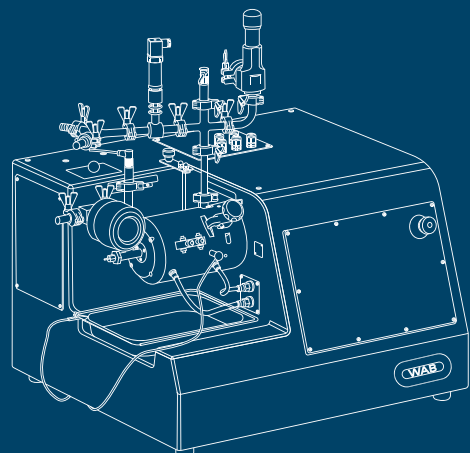

APPLICATION FIELDS

WAB mechanochemical reactors have proven their positive impact to reduce solvents, energy consumption and toxic waste. They improve the conversion, yield and selectivity of the chemical reactions and optimise reaction costs in various application fields.



Pyrotechnics



Food & Beverage



Battery materials



Crop protection



Chemicals



Cosmetics



Electro-technology



Pharmaceuticals



SCAN THE CODE
FOR MORE APPLICATION
CASES!

www.wab-group.com/en/solutions/application-cases/

APPLICATION EXAMPLES: PARACETAMOL SYNTHESIS

Paracetamol is a drug used to relieve pain and reduce fever. In comparison to current solvent-based productions, the process on the **DYNO®-MILL RESEARCH LAB** achieved a higher yield while also allowing the complete removal of the solvents to achieve the desired chemical reaction (Beckmann Rearrangement). Additionally, the synthesis is achieved substantially faster than with conventional methods.

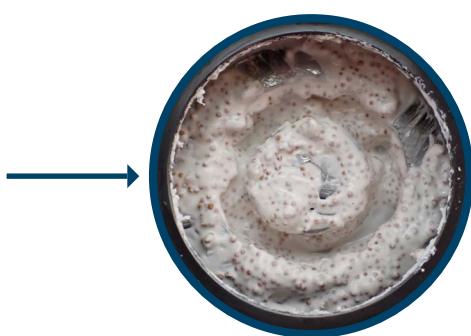
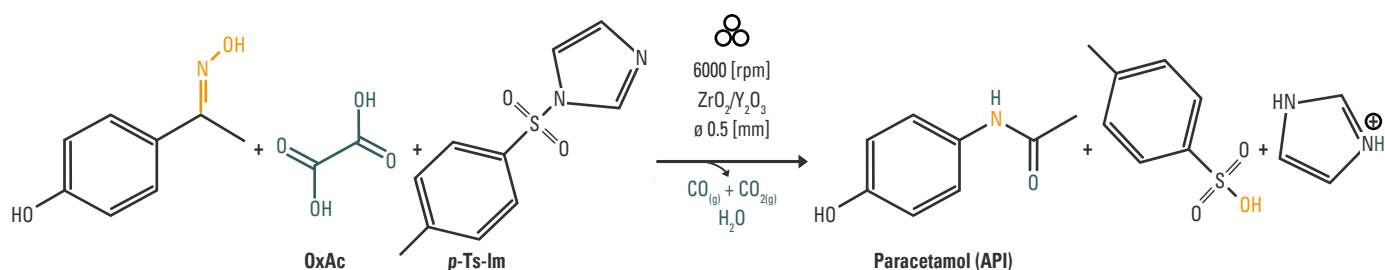

SCAN THE CODE
FOR MORE INFORMATION!

www.wab-group.com/en/solutions/application-cases/paracetamol-synthesis/

R. Geib, E. Colacino, L. Gremaud, ChemSusChem 2024 17 (12), e202301921. <https://doi.org/10.1002/cssc.202301921>

VANILLIN SYNTHESIS

Vanillin is the major component of natural vanilla and an important flavouring agent widely used in the food, beverage, perfume and pharmaceutical industry.

Performing the reaction on the **DYNO®-MILL RESEARCH LAB** and **DYNO®-MILL MULTI LAB** showed a shorter process time, lower process temperature and higher process productivity. The synthesis was achieved without using a catalyst and a scale-up from lab to pilot scale was successfully carried out.

DYNO®-MILL RESEARCH LAB and DYNO®-MILL MULTI LAB

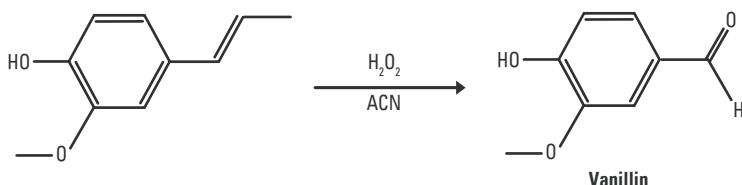

SCAN THE CODE
FOR MORE INFORMATION!

www.wab-group.com/en/solutions/application-cases/vanillin-synthesis/

HYDROGEN
PEROXIDE
+
ISOEUGENOL
+
ACETONITRILE

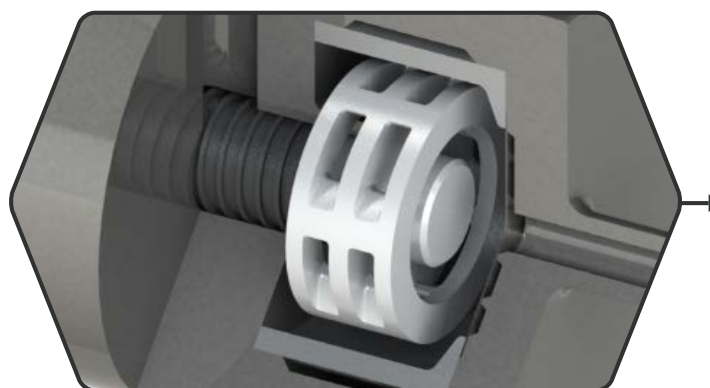
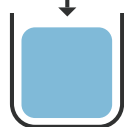

VANILLIN



A. I. Martín-Perales, D. Rodríguez-Padrón, A. M. Balu, S. Halloumi, I. Malpartida, R. Luque, *Industrial & Engineering Chemistry Research* 2023 62 (43), 17545-17552.
<https://pubs.acs.org/doi/10.1021/acs.iecr.3c02250>

CALCIUM ZINCATE SYNTHESIS

Calcium zincate (CAZN) can be used in the production of zinc anode of alkaline electrochemical generators, heterogeneous catalysts for the production of biodiesel or for antifungal products. Most often this product is used for electrodes in zinc batteries.

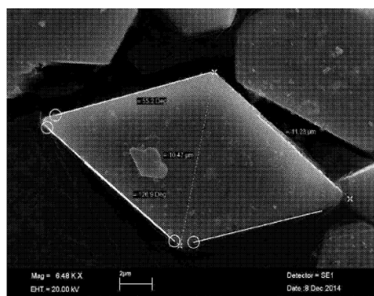

Laboratory tests indicated that using a **mech-anochemical process**, the Calcium Zincate has more reaction surface and a 1.77 times faster activation of the battery. A Life-Cycle Analysis was carried out and showed that the mechanochemical process is a better ecological alternative to hydrothermal synthesis.



SCAN THE CODE
FOR MORE INFORMATION!

www.wab-group.com/en/solutions/application-cases/calcium-zincate-synthesis/

V. Caldeira, L. Jouffret, J. Thiel, F. R. Lacoste, S. Obbade, L. Dubau, M. Chatenet, *Journal of Nanomaterials* 2017, 7369397. <https://doi.org/10.1155/2017/7369397>

WOOD CHIPS COMPONENTS SEPARATION

Processing and depolymerization of wood waste with our **DYNO®-MILL MULTI LAB** allows the extraction of cellulose, hemicellulose and lignin. For instance, cellulosic pulps can be used in sectors such as papermaking or for higher value-added products such as cellophane or rayon.

Hemicellulose can be used to produce biofuels such as bioethanol. Lignin-based products have been proven effective for fertilising, sand-fixing, as bioactive compounds and as adhesives. Compared to conventional hydrothermal process, less energy and less production time is needed.

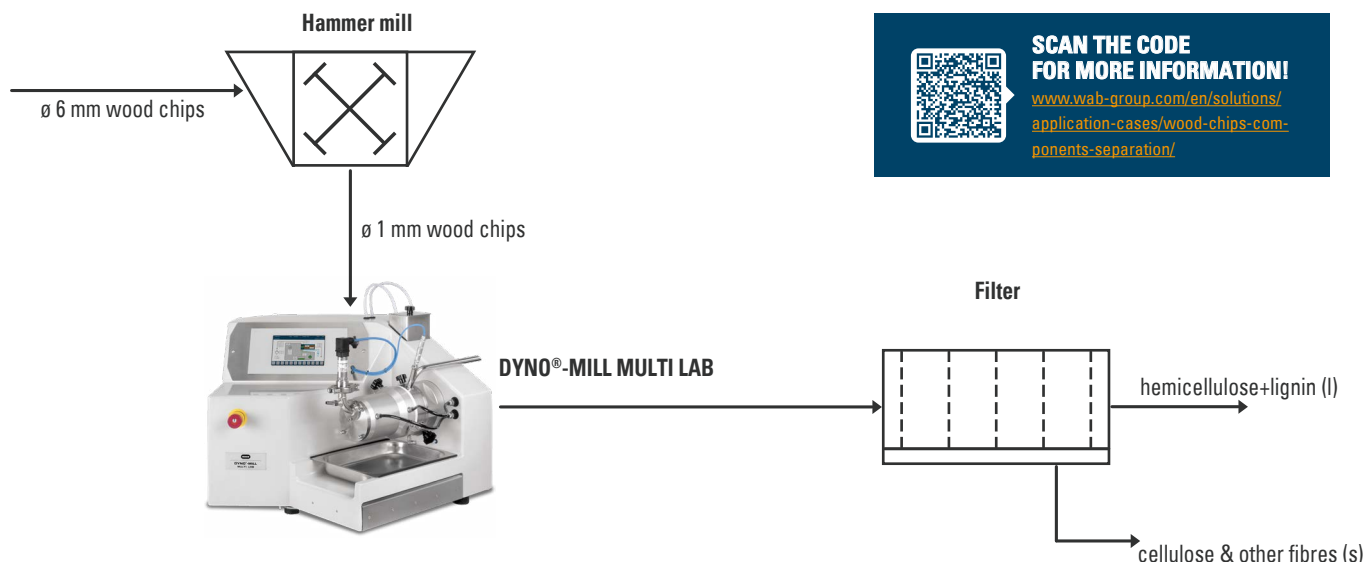

S. Arfelis, I. Malpartida, A. Bala, V. Lair, R. Xifré, R. Aguado, M. Delgado-Aguilar, J. Parduhn, I. Szdovski, P. Fullana-i-Palmer, ACS Sustainable Chemistry & Engineering 2024 12 (13), 5105-5116. <https://pubs.acs.org/doi/10.1021/acssuschemeng.3c07477>

ZINC GLYCEROLATE SYNTHESIS

Zinc glycerolate is used as an additive for the vulcanisation of rubber and in the plastics industry.

WAB IMPA°CT REACTOR® enables a high reaction temperature and is predestined for the production of zinc glycerolate.

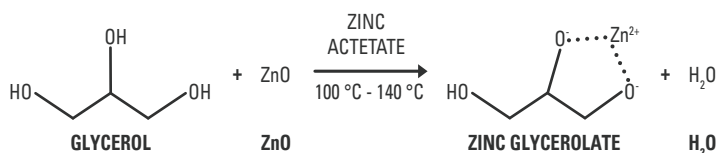

SCAN THE CODE FOR MORE INFORMATION!
www.wab-group.com/en/solutions/application-cases/zinc-glycerolate-synthesis/

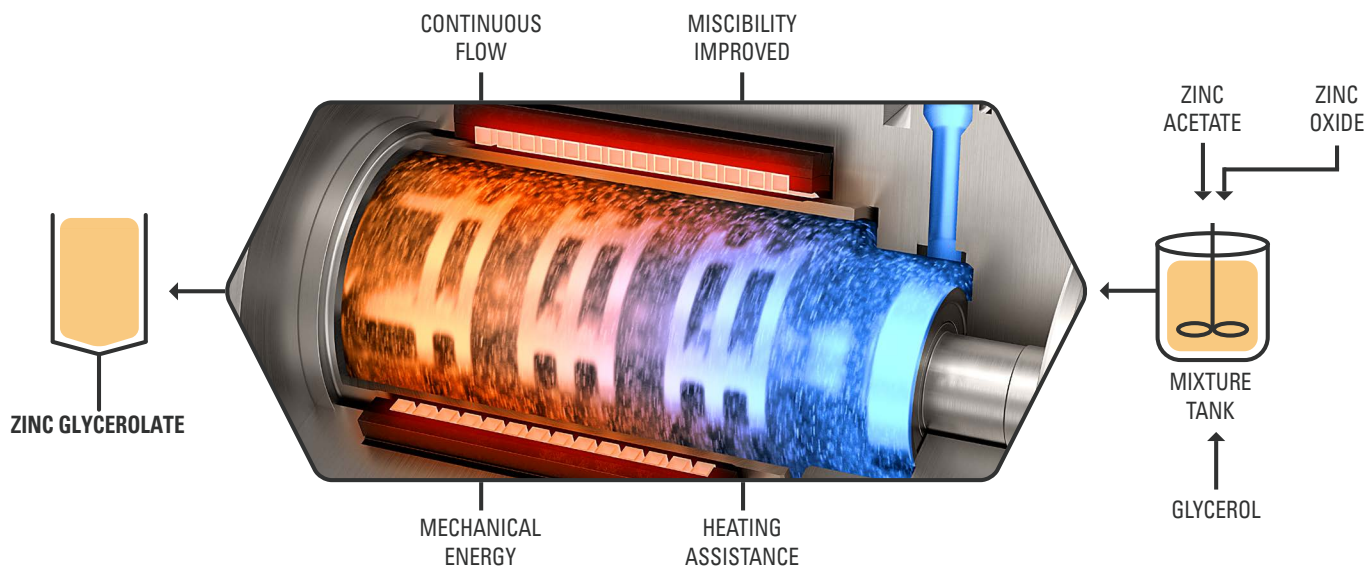

The research was led by Deasyl SA (Switzerland).

TRIALS AT WAB

Do you want to test your processes with our innovative tools? Our expert team is happy to meet you at our worldwide located Process Technology Centres to carry out your trials and to develop your customised solution. We will support you during the whole process - from research to industrial scale-up.



ADVANTAGES

- Research & Development on continuous flow chemistry
- Mechanochemistry from laboratory to production
- Highest flexibility to perform trials with your products
 - ✓ processing of liquids, solids, powders and liquid assisted products
 - ✓ product heating and cooling
 - ✓ operation of explosive solvents
 - ✓ handling of hazardous substances
 - ✓ adding of gases to the process
- Post-treatment and analysis options on demand
- Scale-up trials
- Modern equipment
- Free of charge trials
- Process Technology Centres worldwide
- Professional support from WAB specialists

WAB-GROUP® ENTITIES

WAB-GROUP® is your reliable and global partner. With our local sites and technical specialists on site, we are happy to be at your service as a proficient engineering company and proven process expert. In our production facilities on four continents, we manufacture to the highest quality standards and assure professional and comprehensive support.

Switzerland, Headquarters:

Willy A. Bachofen AG
Junkermattstrasse 11
P.O. Box 944
4132 Muttenz 1
Switzerland
+41 61 6867 100
wab@wab-group.com
www.wab-group.com

North America:

WAB US Corp.
3 Pearl Court, Suite E
Allendale, NJ 07401
USA
+1 973 873 9155
wab-us@wab-group.com
www.wab-group.com

France:

Willy A. Bachofen S.à.r.l.
3, rue Paul Henri Spaak
68390 Sausheim
France
+33 389 31 17 00
wab-fr@wab-group.com
www.wab-group.com

Germany:

Willy A. Bachofen GmbH
Liebigstrasse 16
61130 Nidderau-Heldenbergen
Germany
+49 6187 9394 0
wab-de@wab-group.com
www.wab-group.com

India:

WAB India Pvt. Ltd.
Plot No. D 36/3B
T.T.C. Industrial Area, Turbhe
Navi Mumbai – 400 705
India
+91 22 613 171 00
wab-in@wab-group.com
www.wab-group.com

China, Sales Office:

WAB Machinery (Shenzhen) Co., Ltd.
Room 1710, Kerry Everbright City, Phase 1
No. 218 Tianmu Road West
Jing'an District, Shanghai – 200070
China
+86 21 6380 6481
wab-cn@wab-group.com
www.wab-group.com

China, Headquarters & PTC:

WAB Machinery (Shenzhen) Co., Ltd.
Unit 102, Floor 1, Plant Building 1
Everbrite Technology Park, Mingqing Road
Longhua District, Shenzhen – 518109
China
+86 755 2813 5108
wab-cn@wab-group.com
www.wab-group.com

Israel:

WAB Israel Corp Ltd
17th floor, B.S.R 2 Building
1 Ben Gurion Str., Bnei Brak 5120149
Israel
+972 3 6142303
wab-il@wab-group.com
www.wab-group.com

Contact our WAB-GROUP® locations or one of the numerous partners within our strong network.



**SCAN THE CODE
FOR MORE INFORMATION!**

www.wab-group.com

WAB-GROUP

WAB